



## Video OEM module

### VPROC - 3D

The fourth generation VPROC video switcher/scaler module provides an off the shelf solution for high quality video processing in a number of consumer and professional applications. Based on Sigma Designs (formerly Gennum) VXP device, the VPROC modules are complemented with a range of video I/O interfaces, including support for HDMI 1.4 3D format pass through.

By combining MDS modules manufacturers can have solutions ready for markets with minimal development. Using MDS solutions, manufacturers can focus on the user experience and "front panel" and "rear panel" design and avoid the headaches of the high speed design and complex software for standard audio and video processing functions.

The basic design is can be modified into custom products to meet your specific requirements, please contact the MDS sales department with your custom product requirements. For example the optional input expansion connector can be used to add custom I/O to create a unique product without needing to create an entire video design.

This guide focuses on MDS' video scaler product, for information on MDS' HDMI switcher/repeater, DAE audio products or media processing systems please see the MDS website.

## Product Summary

### HDMI Interface

Four HDMI 1.4 compatible (1080p, 12 bit deep color, 3D) inputs are on the main board; an expansion connector allows the addition of a second set of four HDMI inputs for eight total. Active EQ is used to allow the longest possible cables, typically (for 1080p video) 20m with quality cables.

Two HDMI outputs provide video up to 1080p in 12 bit deep color format including 3D pass through. Audio in the newer HDMI 1.3 High Bit Rate formats can be passed through from input to output or extracted for local processing and stereo PCM sent to a default stereo capable sink device.

The Audio Return Channel (ARC) feature of HDMI 1.4 is also supported on both of the HDMI outputs, though only one can be selected at a time.

### Video Processor Module

Based on Sigma's broadcast quality VXP processor, these modules provide extremely high quality scaling and deinterlacing capability, as well as support for high quality graphics and On Screen Displays (OSD).

The VXP GF9452 processor is used to process 2D video (deep color and standard colorspace) provides for picture improvement of HDMI 1.3 formatted video and analog inputs.

When in pass-through mode with 3D content the VXP can be used (with restrictions) to create a small OSD overlay for status like a volume control indicator or source selection

### Development Platform

VDP-3 - Development/demonstration platform for VPROC. Allows the proto-typing of applications on its powerful 32 bit ARM based host processor. Source code and schematics included.

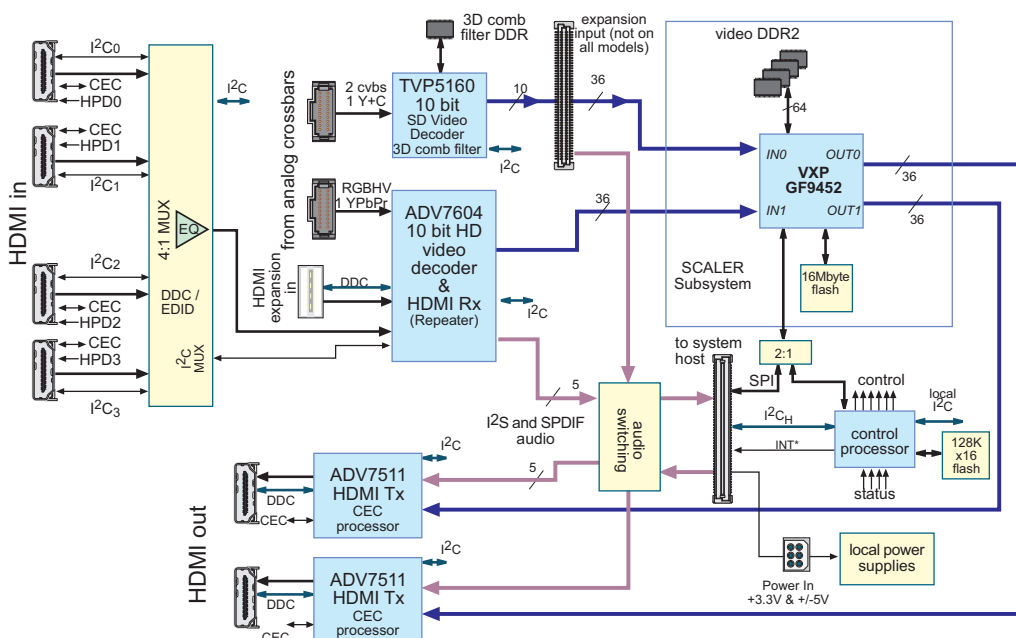

VPROC video processor system

# VPROC-3D Video Processor Module

## Introduction

The video processor modules take in analog video (CVBS, S-video, component, or VGA/RGB) or HDMI video and can perform deinterlacing, scaling and picture quality improvement. Based on Sigma Designs 12 bit VXP9452 broadcast quality processors, the VPROC provides a direct control interface to the VXP so that product developers can take advantage of Sigma's Viper software tools for on screen display (OSD) application development.

The VPROC modules are complete video systems; add jacks, analog muxes, and a host control processor and you have the hardware for a complete video processor ready for your host software.

MDS can also offer customized version that offer just switching capability or more sophisticated multi input/output options. Please contact MDS' sales department with your requirements.

The VPROC also passes I<sup>2</sup>S or SPDIF audio from the HDMI receiver to the host system, and can output I<sup>2</sup>S or SPDIF audio as well. The VPROC can be used with MDS' DAE-6D or DAE-77 Digital Audio Engine products, which have specific features to handle I<sup>2</sup>S based HDMI audio (PCM and the new high bit rate Dolby/DTS formats) as well conventional Dolby or DTS 5.1/7.1 surround sound decoding. Other DAE models can also be integrated with the VPROC.

## VPROC

Full details of product use and operation are available in the product manuals; the sections that follow are intended to provide some level of understanding of the details so that integration into systems can be better understood.

The VPROC design represents considerable effort at creating a platform that is both powerful and flexible enough to be used in a wide range of applications yet retain "ease of use" for the integrator.

### Analog video inputs

The two analog input connector provides separate inputs for each style (SD vs. HD) of video to simplify the design of an external analog video mux. All inputs are 75 ohm impedance and offer adjustable gains and/or AGC to provide optimum dynamic range.

- SD: CVBS input and Y/C (S-video) input  
- advanced 2D/3D comb filter
- SD/HD: one YPbPr input and one RGBHV input

The analog video uses 26 pin AMP 6-104068-2 high density connectors; with the corresponding ribbon cable a 75 ohm impedance is maintained.

As input muxing is normally controlled by the host processor, the connectors also carries I<sup>2</sup>C and a "user" pin so that

the VPROC host connector can be used to control input selection without extra cables to the muxes.

It is worth noting that the composite input uses one of the best available video decoders with a 3D comb filter to minimize artifacts related to NTSC/PAL video. While this may seem like an anachronism in today's high-def world, many camera, portable video players, and hand held games include composite video out as a feature. The 3D comb filter ensures the best possible video from such devices. Noise reduction features are also available for handling legacy sources like VHS.

### HDMI 1.4 video

While there are almost no sources for content with more than 8 bit resolution, or content other than YUV or RGB format, customers looking to future proof systems will look for the capability to handle deep color video.

The VPROC-3D module supports 12 bit deep color (YUV or RGB) with full processing at up to 1920 x 1080 image size. 3D formats are not supported by the VXP so they are passed unchanged from input to output.

### Cable EQ

All HDMI inputs include automatic cable equalization paired with host controlled settings to support up to 20 meters of input cable (typical, with 1080p source on 24 AWG HDMI cables).

### CEC handling

The module provides flexible access to the CEC lines. A small processor on the card (part of the HDMI Tx part) manages (the bit banging for) receiving and sending CEC messages. The VPROC's processor then further processes messages so that the system's host processor is only responsible for acting on relevant messages. These processors are powered by a standby supply so that CEC messages can be acted on while the system is in a sleep state.

### HDMI receiver

The HDMI receiver supports all features for video formats in HDMI 1.4. Audio is routed to the system host processor board; units that do not require audio processing can loop the output back; however this assumes that the downstream devices can add audio delay to match the video processing delay of the system or the upstream device supports the lip sync feature of HDMI. If the system brings in analog video it may be desirable to place ADCs in the system to put the audio from analog video sources onto the HDMI connection.

The VPROC implements HDCP repeater functionality and supports the CEC addressing requirements.

### Expansion input (option)

A 36 bit parallel video input is provided to allow connection to other video sources via a daughter card. For example a custom board for SDI video.



PRELIMINARY - SUBJECT TO CHANGE

17330 Brookhurst St., Suite 230, Fountain Valley, CA 92708  
Phone: 714-378-5805 / Fax: 714-378-5985  
<http://www.mds.com>

# VPROC-3D Video Processor Module

## Dual output

The standard module incorporates a second output to avoid the need for an external HDMI repeater/splitter. If building a video-only processor it is typically necessary to route the video to the display device and the audio to the surround sound (AV Receiver) system.

Simple Y configurations can not be implemented due to the deficiencies of the HDCP encryption system.

Note that the same video stream is sent to both outputs.

The GF9452 does support dual stream processing, so if a second (custom) input board is added to the VPROC via the input expansion connectors, then it is possible to processed two zones or offer Picture-in-Picture capability. Support of extra capability such as this may entail MDS engineering charges, please contact MDS with your requirements.

## HDMI expansion board

This connector allows the VPROC's microprocessor to perform the control functions needed to select inputs for the optional 4 channel input expander.

## HDCP keys

The VPROC uses HDMI Rx/Tx parts with internal keys. Please contact MDS regarding HDCP licensing issues.

Also, HDCP rules forbid analog output from HDCP content, so the VPROC system can not be modified for analog output. Analog pass-through from analog input(s) can be done on the analog muxing/switching boards, if needed.

## Mechanical

The board is approximately 7" x 8" (180 mm x 200 mm). Nine mounting holes provide support. The 4000 series is backward compatible on all mounting holes and the HDMI and host connector types and locations to the earlier 3000 series.

## Power

The board requires external +5 and +3.3V supplies. If CEC is implemented, power to the board must be maintained. The board can be commanded into a low power standby state where only CEC is processed.

## Control interface

The board is controlled through commands sent over the I<sup>2</sup>C interface to the control processor. Once commanded to select a particular input, the control processor interrogates the HDMI sink device(s) and determines the best output resolution, and then sets the scaler to perform the needed conversions and picture quality improvements. The host may then override specific settings.

The VPROC's control processor and VXP arrive from the factory configured to display basic OSD and status information.

The host can request direct access to the VXP SPI port. This allows the host program to display complex OSD for menu, status, etc. Sigma's Viper software (OSD builder) can be used for this purpose.

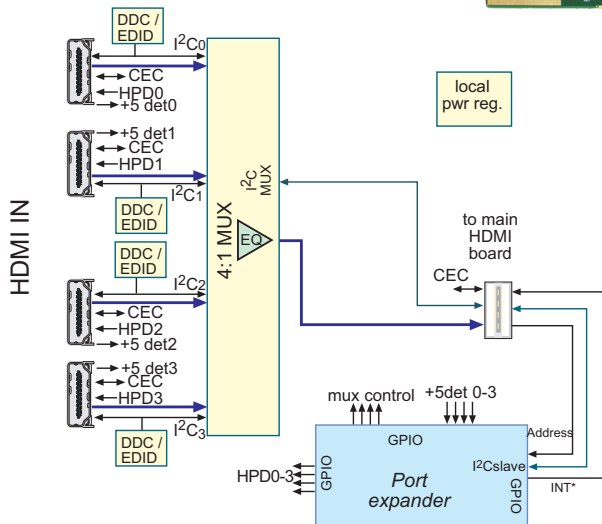

**HIB-4 expansion module allows for 8 HDMI inputs**

## VPROC details

The VPROC contains a number of features to simplify control of analog multiplexer boards that would normally connect to the VPROC board.

As illustrated in the figure below, a number of independent I<sup>2</sup>C paths are available to allow the host to directly control

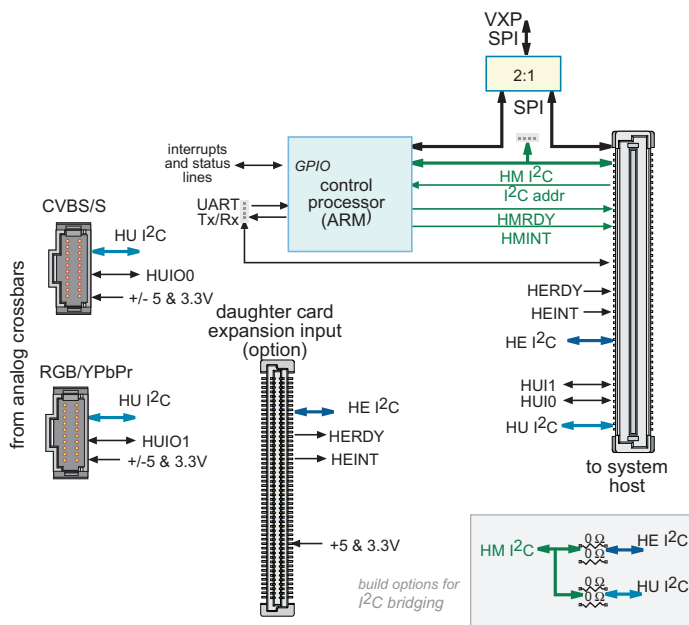

Flexible control paths support different design implementations while minimizing cabling between modules

rear panel I/O selectors. For example the VDP comes with mux boards for SD and HD analog video inputs, the design of which illustrates how to use this capability and can serve as the basis of your own custom system.



VDP development platform

## Video Development Platform: VDP

### Introduction

The video development system provides an environment for complete application development using the modules described in this datasheet.

As shown in the block diagram below and on the next page, the development system offers a rich range of inputs and outputs that are typical of high performance video systems.

The same high quality design found in MDS' module products is also reflected in this system. The system is provided with schematics and source code to the demonstration control application, providing you with a starting point for your own custom system design that will save months off of the development process.

### System capability

Based on the VPROC module, the Video Development Platform provides broadcast quality video scaling and deinterlacing at the output.

### Custom units

MDS can offer custom versions of either module level products or a complete platform design based on the Video Development Platform unit. Please contact MDS with your requirements.

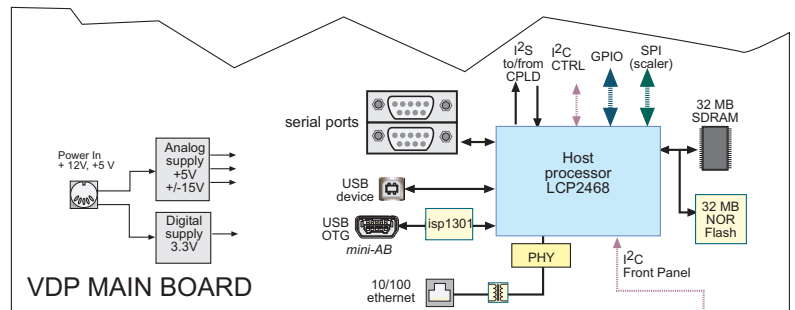

VDP MAIN BOARD

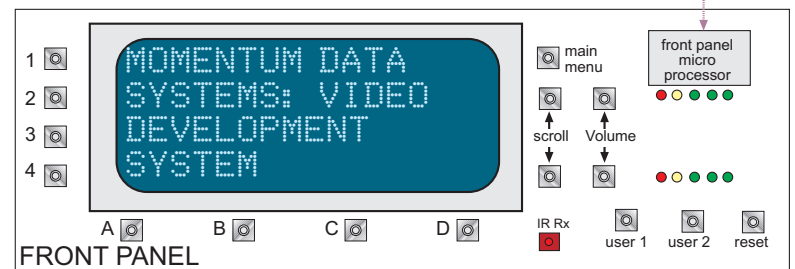

VDP control processor and front panel

PRELIMINARY - SUBJECT TO CHANGE



17330 Brookhurst St., Suite 230, Fountain Valley, CA 92708  
 Phone: 714-378-5805 / Fax: 714-378-5985  
<http://www.mds.com>

# Video Development Platform

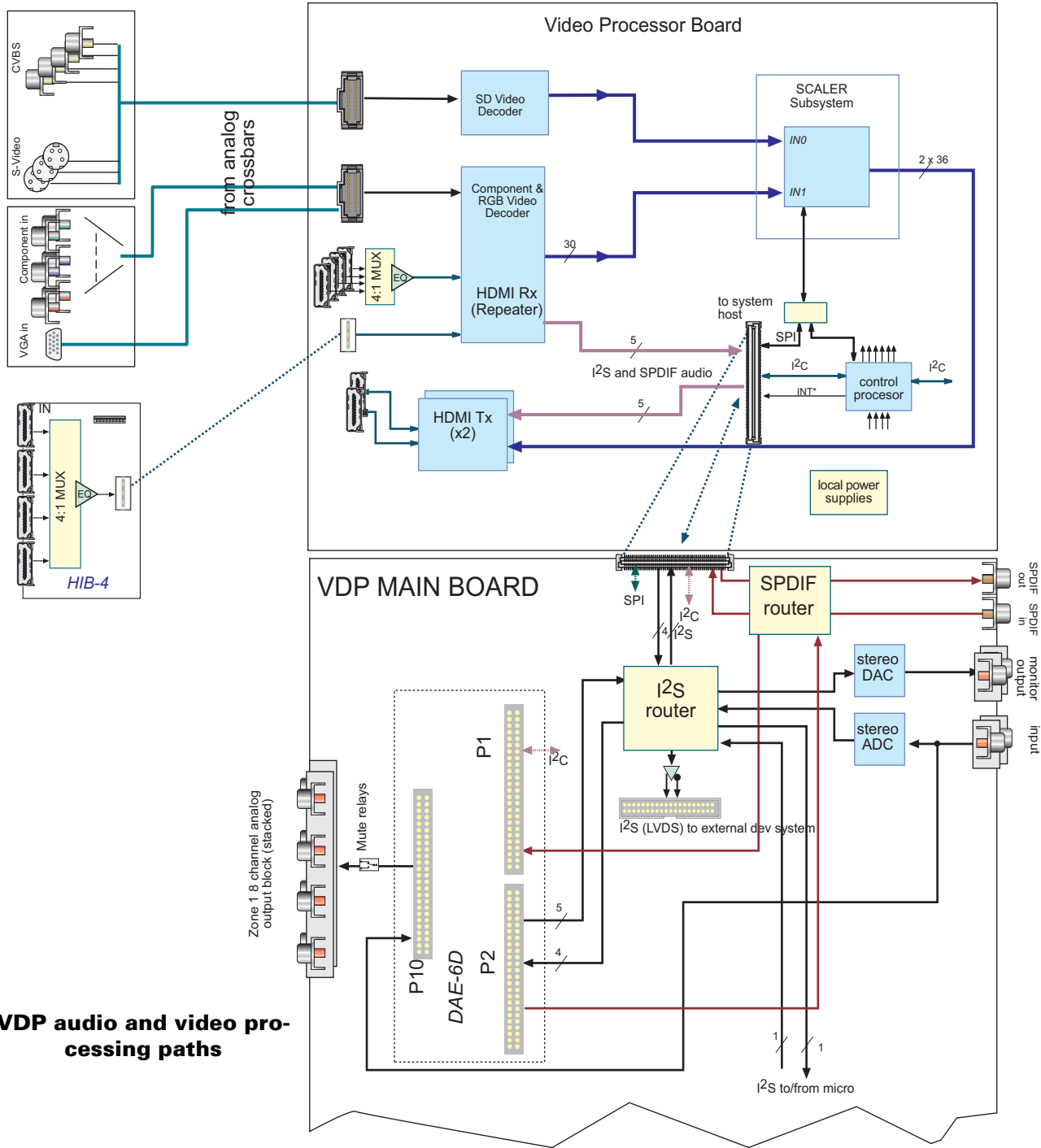

**VDP audio and video processing paths**

**VDP development platform rear panel**



PRELIMINARY - SUBJECT TO CHANGE



17330 Brookhurst St., Suite 230, Fountain Valley, CA 92708  
 Phone: 714-378-5805 / Fax: 714-378-5985  
<http://www.mds.com>

# Product Summary

## System usage details / FAQ

- Since there are two HDMI Tx parts does that mean I can use two CEC trees?

While there is independent hardware, the ADI supplied drivers for CEC do not handle more than one device. A custom software implementation could support it.

- Since there are two HDMI Tx parts does that mean I can use two ARC (Audio Return) channels?

Only the ARC of the output using CEC can be active (i.e. only one source at a time).

- Are the two HDMI Tx the same?

Yes, they carry the same video and audio output data. However there is one subtle difference in capability: The primary output CEC is connected to the input side CEC. The secondary output CEC is not used for the reasons above and there for ARC is not supported on the secondary output.

- What processing is done on 3D video?

None, it is only passed through. The VXP part does not handle 3D images - while processing could be enabled there is the potential to create unintentional artifacts.

- The analog video inputs seem different than previous VPROC models?

The ADV7604 used on the VPROC has a general input cross bar that allows more flexibility than the earlier models. However for backwards compatibility the same connector usage is retained.

- I need analog video output.

Unfortunately the use of HDCP with HDMI precludes any analog output of any sort. If you need a "zone 2" or "analog video pass through" type capability you will need to build that into the analog video input multiplexer board.

Please contact MDS regarding use of products containing licensed HDCP technologies.

Modules with HDMI are tested and certified by HDMI compliance testing services but custom systems may also require final product level certification.

## Ordering information

*VDP*: Video Development Platform.

- Complete box level system with application software for basic operation of the unit from front panel or via I2C adapter from PC.
- Rear panel video cross bar/mux boards with:
  - 4 CVBS inputs
  - 4 S video inputs
  - 3 component video input
  - VGA input (up to 1600 x 1200)
- 8 HDMI in
- 2 HDMI out
- Audio I/O:
  - stereo analog input
  - SPDIF input
  - stereo analog output
  - SPDIF output
- VPROC module (VPROC-3001)
- Character LCD front panel with ARM based microprocessor
- Schematics to host board and analog muxer boards and host software source code included.
- serial to I2C adapter for direct control of VPROC

*VPROC*:

- Single zone scaler/deinterlacing with VXP technology.
- See table below for ordering codes.

*HIB-4*: HDMI expansion card

- For use with VPROC-3D
- Provides 4 HDMI inputs (8 total)
- Connects to VPROC card for control

product ID	HDMI in	HDMI outputs (up to 1080p)	Daughtercard connector
<i>VPROC-3001</i> *	1080p/HDMI 1.4	2	No
VPROC-3004	1080p/HDMI 1.4	2	Yes

\* italicized entries are standard configurations and can be ordered in quantities of 25 or more. Other configurations may have minimum order size.

## Trademarks:

Dolby is trademark of Dolby Laboratories, Inc.

DTS is a trademark of Digital Theater Systems, Inc.

HDMI, the HDMI logo and High-Definition Multimedia Interface are trademarks or registered trademarks of HDMI Licensing LLC.

HDCP is a trademark of Digital Content Protection, LLC.



**PRELIMINARY - SUBJECT TO CHANGE**

vproc-3D datasheet rev1d Feb 11

17330 Brookhurst St., Suite 230, Fountain Valley, CA 92708

Phone: 714-378-5805 / Fax: 714-378-5985

<http://www.mds.com>