

DAE - 6D™

High Performance AV Receiver Module

TEXAS INSTRUMENTS DA710 DSP based OEM Audio Module

The DAE-6D AV Receiver module provides a complete surround sound decoder system for the latest generation of audio applications. With full support for the latest Dolby and DTS HD formats, and enough post processing power for world class bass management processing, parametric EQ, and sound field enhancement, the DAE-6D can make a great audio system into an outstanding one. With optional room EQ from Audyssey and Trinnov, no other solution provides the quality level and feature integration of the DAE-6D.

To reduce development time and expense, the DAE-6D is available with a complete development system called the ADP that includes schematics and all source code for the host system.

Hardware Features - general audio I/O

- S/PDIF in up to 96 kHz
- stereo audio in, 24 bit 192 kHz.
 - o 110 dB dynamic range. 100 dB THD+N
- 8 channels audio out, 24 bit up to 192 kHz.
 - o 112 dB dynamic range. 102 dB THD+N

Hardware Features - I²S audio I/O

- Four I²S inputs up to 192 kHz
 - o external clock for HDMI sources (including HBR audio)
 - o internal clock for 7.1 analog in
- Stereo mixdown I²S output

Hardware features - DAE-6 module

- Dual second generation DA710 native 32 bit floating point DSP (140 dB equiv. resolution) with 64 bit floating point for use in critical calculations
- 32 MB memory
- I²C host processor control interface
- Stable crystal oscillator clocked D/A output with ASRC dejitters all digital sources; bypass mode for direct A/D to D/A operation

Companion expansion cards

- 6 additional channels of A/D for 7.1 analog input
- HDMI cards (all support HDMI 1.4/3D video):
 - HSR-8-3D : 8:1 HDMI repeater (expandable to 12 in) with dual output
 - HSR-5: low cost 4:1 HDMI repeater module with basic OSD
 - VPROC: full featured video switching/scaling/picture improvement subsystem with HDMI and analog video, high quality OSD

Off board features that can be added

- PGA for volume control (needed if analog bypass is added)
- PGA for A/D gain trim
- Stereo DAC for monitor out

In the default configuration the DACs are used for volume control. External PGA can be added and host can read the DAE for both volume and per channel trims.

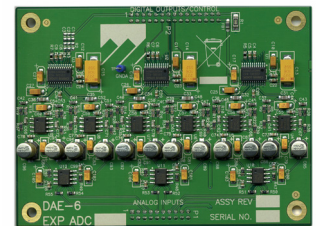
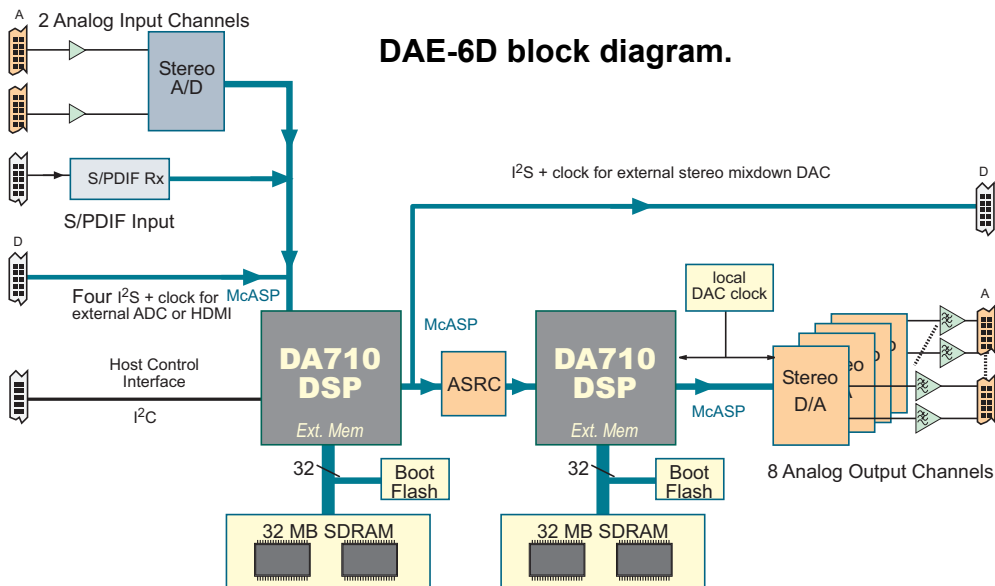

ADC expansion card provides 8 analog input channels total

DAE-6D : High performance AV Receiver system

Software Features

- Decoders
 - Dolby TrueHD and Digital Plus
 - DTS HD Master & High Resolution audio
 - DTS-96/24, DTS-ES Discrete
 - Dolby Digital
 - PCM-96/24
 - AAC (optional)
- Matrix Processing
 - Pro Logic II, Dolby Digital EX
 - DTS-ES Matrix, DTS Neo:6 2-channel
- Post Processing
 - Comprehensive Bass Management
 - Tone Controls, 7-Channel Stereo/Mono
 - Double Bass Mode, Loudness control
 - Soundfield effects (i.e., Studio, Club, Hall, Cathedral, Movie/Theater, etc., 18 total)
 - Optional THX Ultra 2, Virtualization
 - Optional Dolby Volume
 - Parametric EQ, Graphic EQ
 - Multiple subwoofers, Reverberation.
- Performance Audio Framework supports 3rd party ASP add-ons
 - Optional room EQ from 3rd parties is available

Accessory Modules

ADC-6

This module allows for 8 total channels of analog input in a DAE-6 based system.

Development platform

The ADP development platform allows a DAE-6D, HSR-4 or HSR-8, and ADC-6 modules to be connected.

It provides a complete front panel with a character based display to allow prototyping of user interfaces. Two NXP ARM-7 based processors are in the ADP. One, in the main board, controls all of the modules and provides serial port and USB interfaces to allow development of customer application directly on the ADP. The other is located on the front panel and abstracts the user interface from the main control functions.

The ADP is provided with source code and schematics to the board to reduce the effort needed to design an AV Receiver around the DAE-6D.

Alternately MDS' AVP platform can be used. This unit incorporates both the DAE-6D and the VPROC video processor and serves as an excellent starting point for creating a full audio and video system.

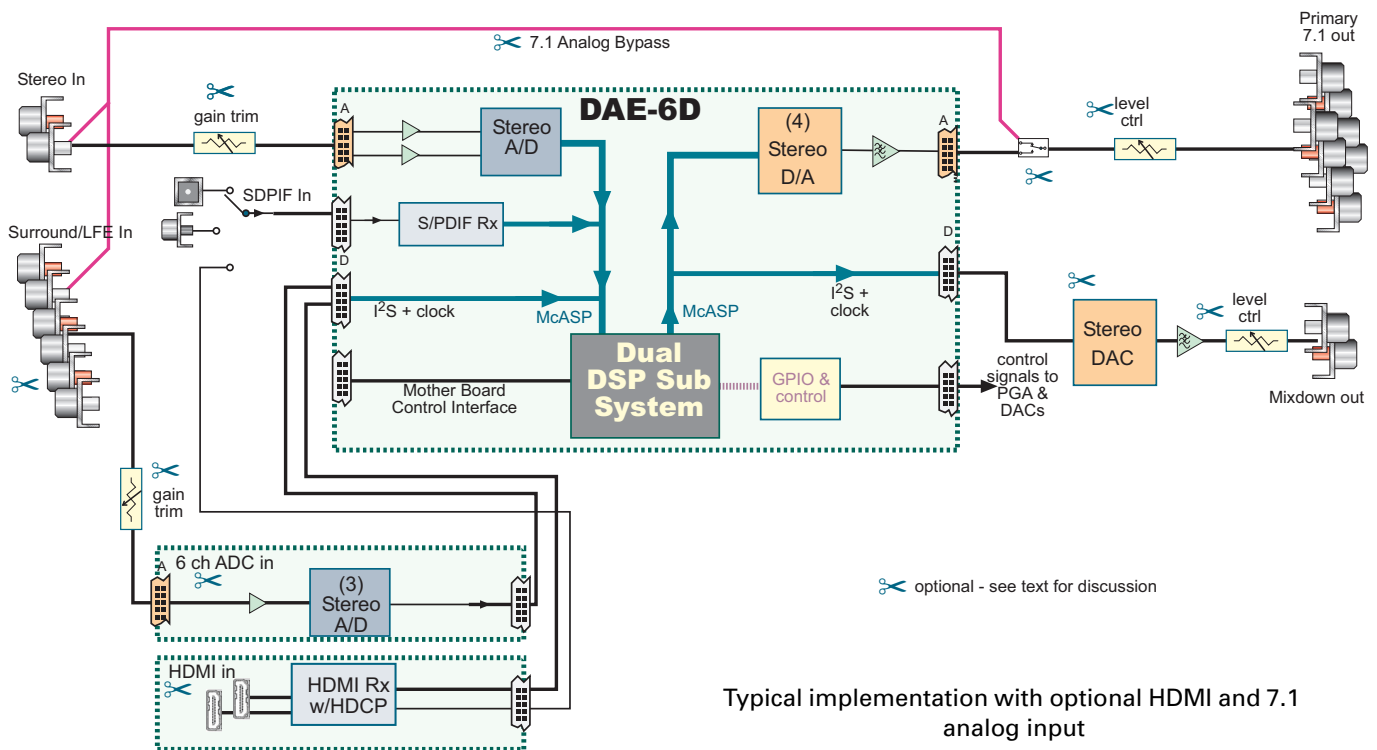

Typical implementation with optional HDMI and 7.1 analog input

DAE-6D : High performance AV Receiver system

Ordering information (order code is in *Italics*)

Shipment of DAE-6 product requires appropriate license from Dolby Labs and DTS. THX available as an option.

Systems are subject to minimum quantities, please contact MDS sales department for a quotation

DAE-6xxx: DAE-6D unit with 300 MHz DA710 processor for AV receiver applications

6xxx represents specific model numbers that may or may not contain optional features. Some features may incur additional charges for porting or per unit license fees.

ADC-6: 6 channel ADC module

ADP: AV Receiver development system with DAE-6xxx, HSR-5, and ADC-6 modules installed

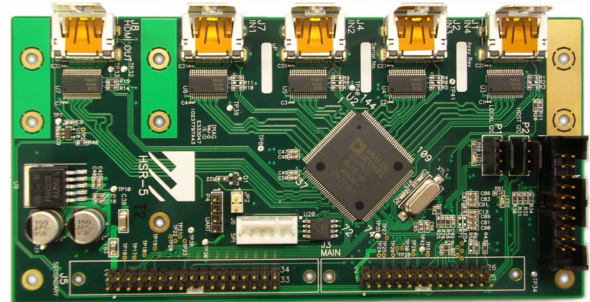

HSR-5 HDMI repeater with OSD.

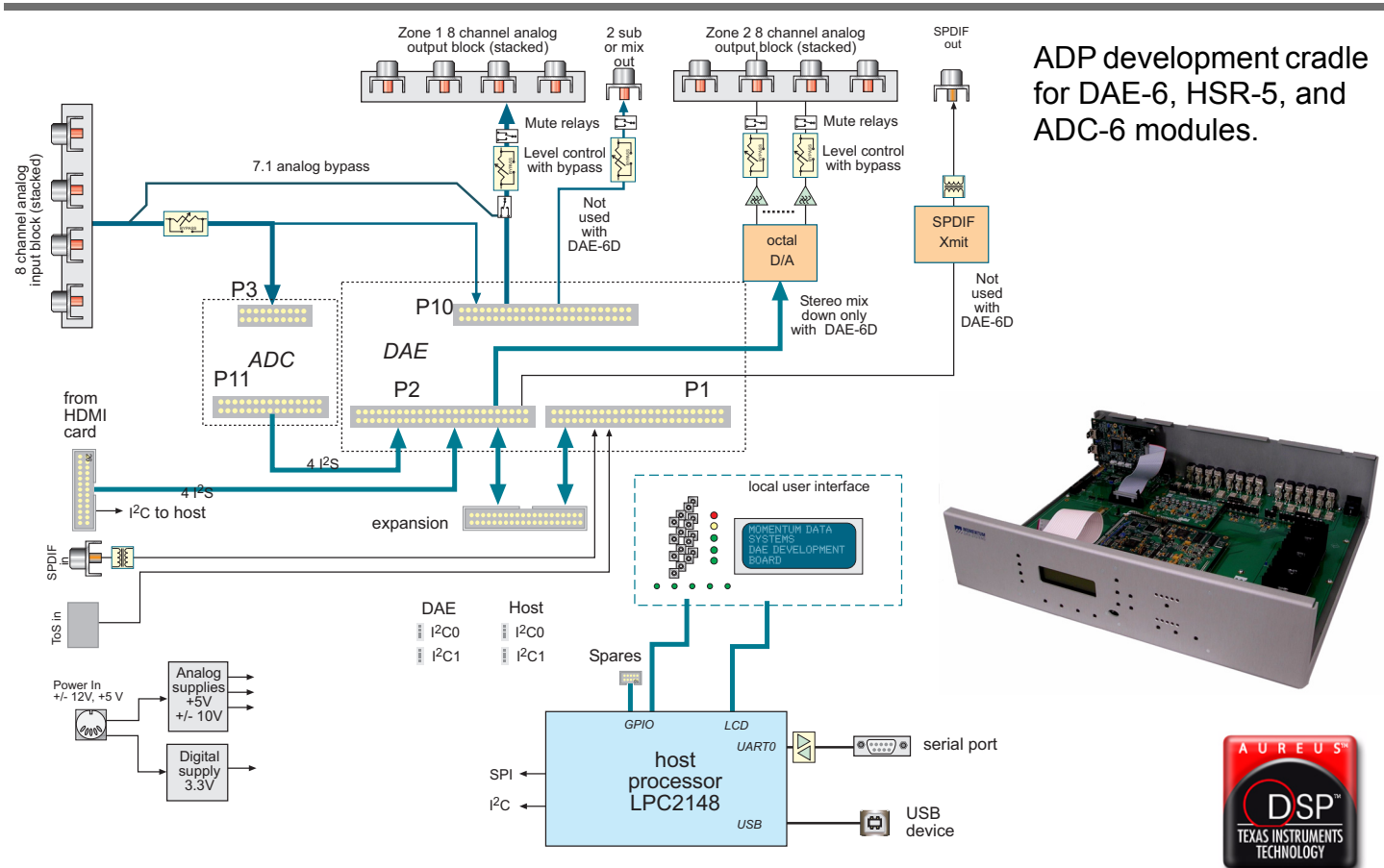

Dolby is trademark of Dolby Laboratories, Inc.

DTS is a trademark of Digital Theater Systems, Inc.

THX is a trademark of THX Ltd.

Aureus, TMS320, TMS320DA61x, DA61x, DA7xx, DSP/BIOS, RTDX, Code Composer Studio, TMS320C6000 and TMS320C67x are trademarks of Texas Instruments.

DAP, DAE, DAE-6D, and DDB are trademarks of Momentum Data Systems, Inc.



Preliminary, Subject to Change. DAE-6D rev 5e, Mar 11

17330 Brookhurst St., Suite 230, Fountain Valley, CA 92708
 Phone: 714-378-5805 / Fax: 714-378-5985
 email: sales@mds.com / web URL: <http://www.mds.com>